

Rev	Date	Changes	Approved By
A	3/18/05	Original	Alan Elyousfi

**1.0 PURPOSE:**

1.1 To adjust a Vacuum Jacketed Manifold Assembly with CPC positioner and actuator. This assembly is used on the REAL-30 model.

**2.0 SCOPE:**

2.1 This document details the procedures required to adjust the valves on a CPC vacuum jacketed manifold valve assembly.

**3.0 REFERENCES:**

3.1 Drawing #11060092

**4.0 DEFINITIONS:**

4.1 Valve Stem: Top portion of the valve that is connected to the valve seat. Moving the stem up moves the valve seat up and vice-versa.

4.2 Actuator: Actuator is connected to the valve stem and converts a pressure input signal into vertical translation of the valve stem.

4.3 Positioner: Part that converts the 3-15 PSIG control pressure signal to a higher pressure signal used by the actuator.

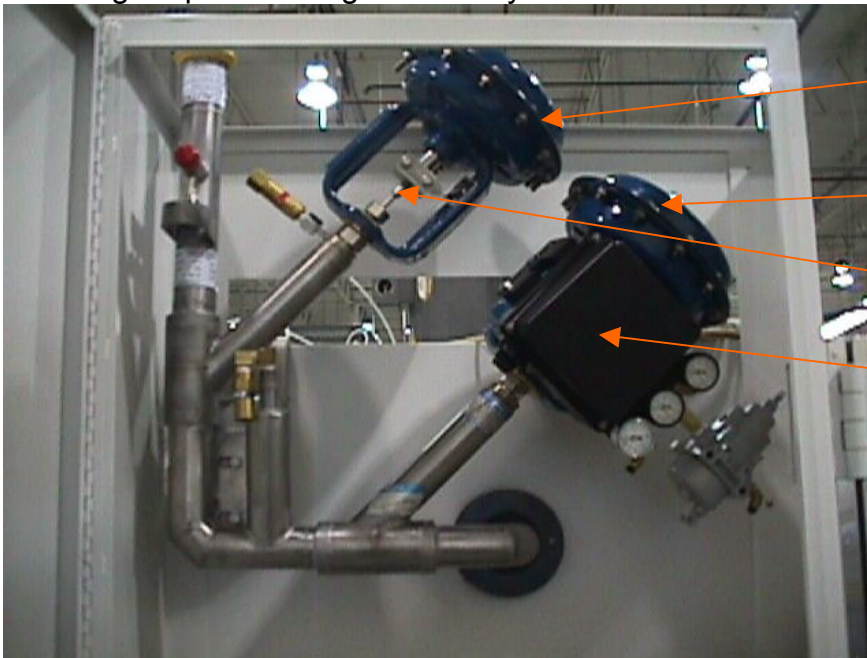

Safety Valve  
Actuator

Control Valve  
Actuator

Valve Stem

Positioner

**5.0 DEFINITIONS:**

5.1 Before beginning the adjustment, drain any liquid nitrogen and pressure out of the system by closing the liquid nitrogen supply to chamber and commanding the chamber to cool for five minutes.

5.2 After pipe section has drained all liquid and pressure, stop the chamber.

5.3 **Valve adjustment (Steps 5.4 to 5.9)**

5.4 With the cooling event set to 'ON', go into the 'Controller Configuration'

menu then to the 'PID Loops' menu. Under the temperature cooling section set the output field to 100% by touching the screen where the value is displayed. A keypad will open up for you to type in 100. This will raise the valve seat off its' base and ensure no damage to the seat.

5.5 Loosen locking collar on both CPC actuator's using ½" wrenches

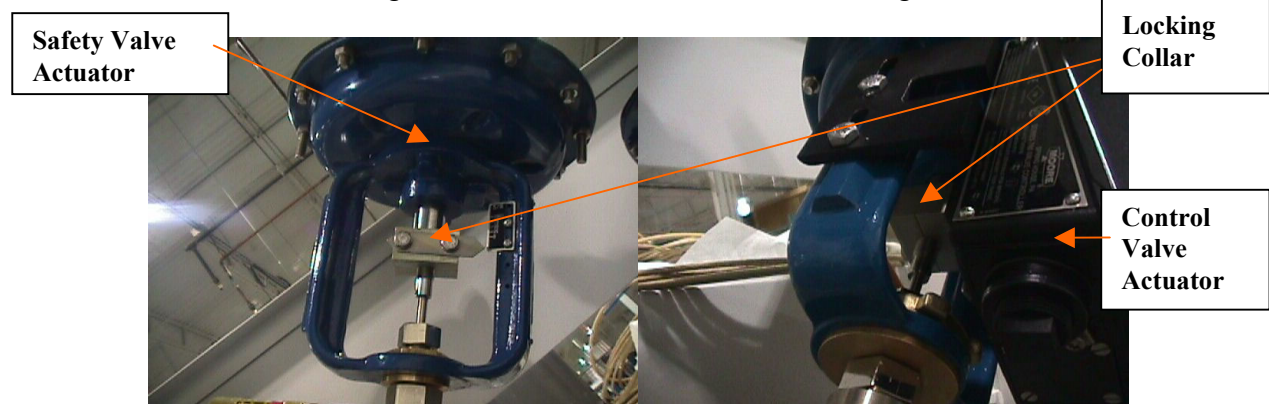

5.6 Turn the valve stem upwards into the actuator (left to right) with a pliers or vise grip until it stops (the small allen bolt head may be helpful in gripping the step). Do this on both actuators.

5.7 Turn the cooling event off so that both actuators go to their closed position.

5.8 Turn stem downward (from right to left) until you feel medium resistance (this is the valve seat closing fully into its' base). Do this on both actuators. Again turn the cooling events on and set the cooling output to 100% as described above. Continue turning the valve stem right to left (2) additional full turns on both actuators. This will assure proper back seat pressure on the valve.

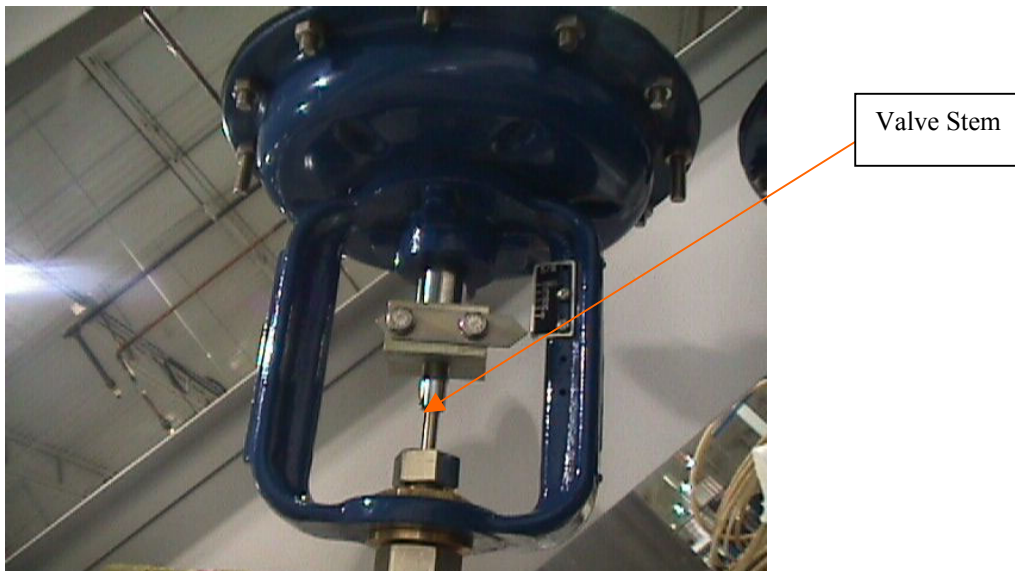

- 5.9 Tighten locking collars on both valves back and turn off cooling event on chamber.



- 5.10 **Positioner Adjustment Steps (5.10 to 5.15)**: Loosen (4) flat head screws from positioner cover and remove.

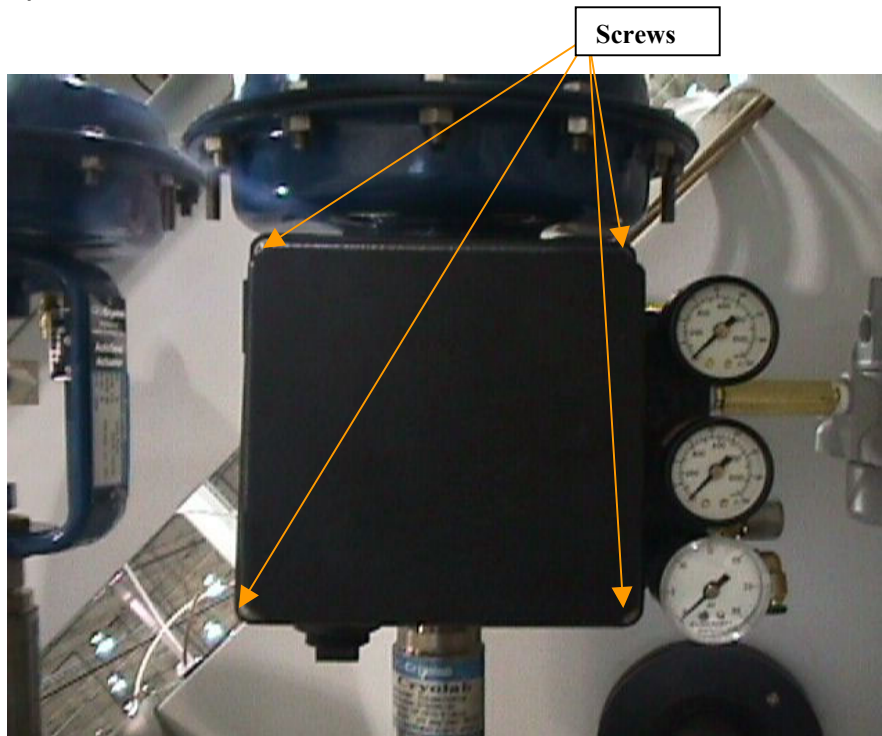

- 5.11 Loosen cam locking screw  
5.12 Loosen knurled cam locking nut

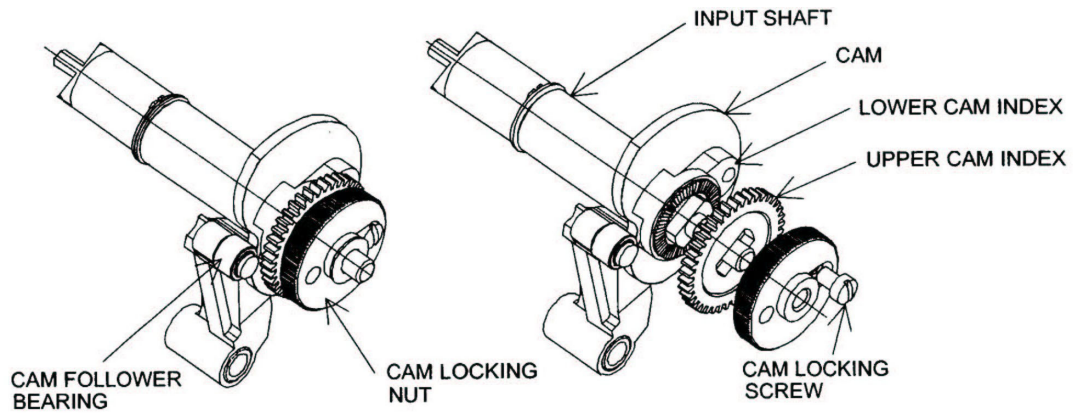

- 5.13 Ensure that the valve actuator is in the fully closed position (cooling event off will ensure this).
- 5.14 Align the minimum input index (small triangle) on the cam with the cam follower bearing.

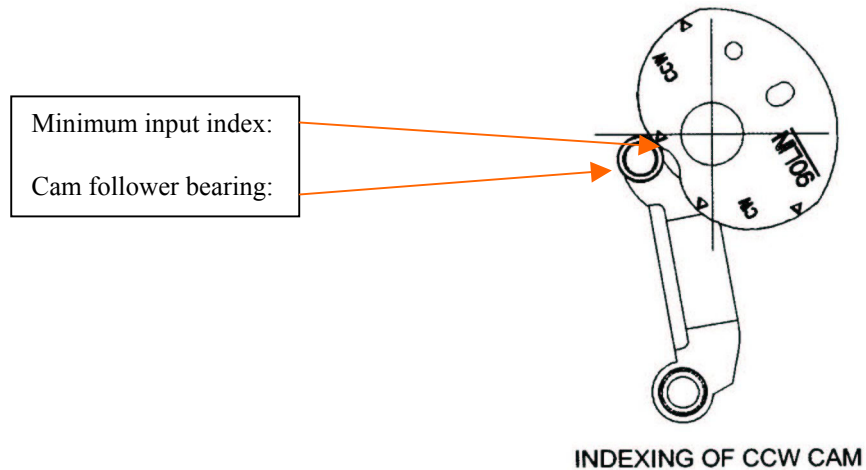

- 5.15 Power on the chamber and turn on fans and cooling from the “manual mode” portion of the controller. Gauge #3 should read 3 psig.

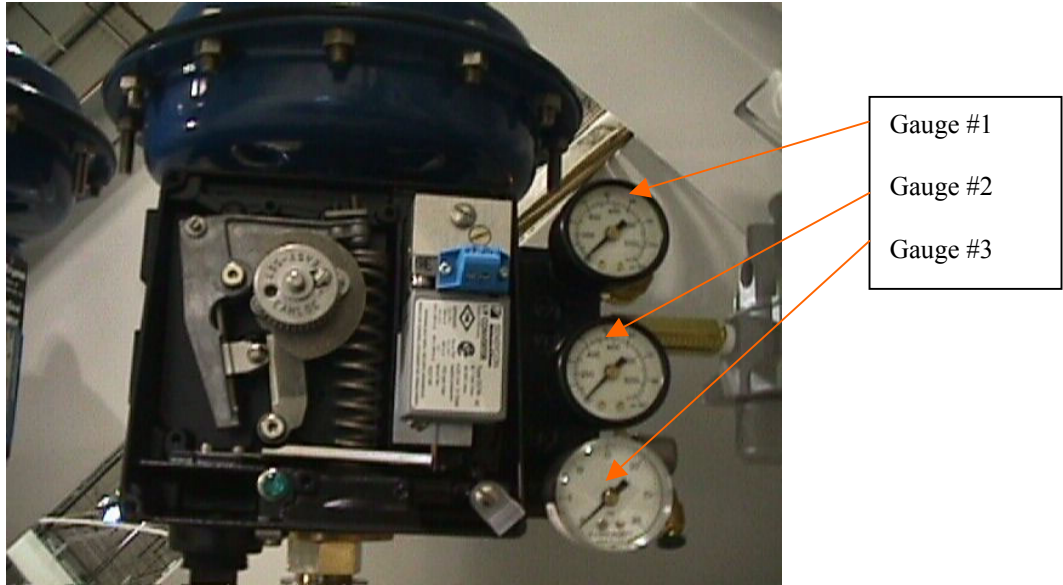

#### 5.16 Zero adjustment

With your finger, place slight upward pressure on the summing beam lever (see figure below), if the valve stem does not move upwards (open) at all, loosen the zero lockscrew and turn the zero adjustment screw counter clockwise in  $\frac{1}{4}$  turn intervals until the valve moves slightly upwards with slight pressure. The zero setpoint on this positioner has now been set.

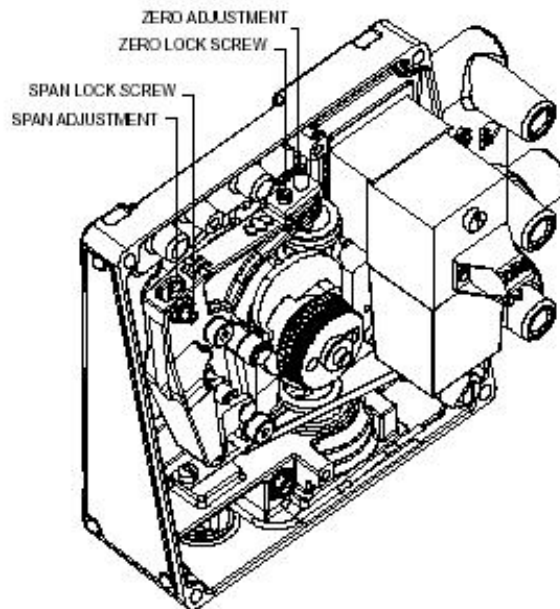

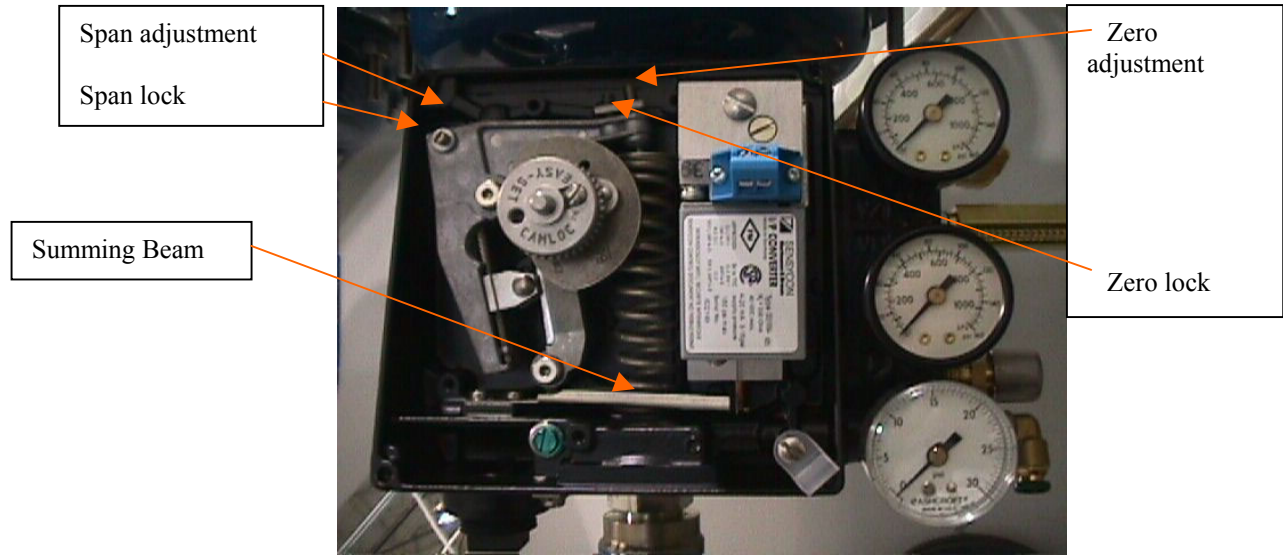

- 5.17 The valve needs to be fully open when the chamber is at 100% cooling. The valve span will need to be adjusted to confirm this action. You will need to run the chamber at 100% cooling with the nitrogen supply valve still closed. To do this, go to manual mode and ensure that fans and cooling events are on, then go to controller configuration, then PID Loops, then Temperature. From this screen manually set air cooling output to 100 by touching the output field and entering 100. Gauge 3 should now read 15psi. If you put slight upward pressure on the summing beam and the valve stem does not rise, then it is open all the way and proceed to step 5.20. If it does move upwards (rise), then go to step 5.18.
- 5.18 The span is not opened 100% and will contribute to the chamber not cooling properly. The span adjustment screw will need to be turned counter-clockwise until the valve does not open with slight upward pressure on the summing beam, before doing this loosen the span lock screw.

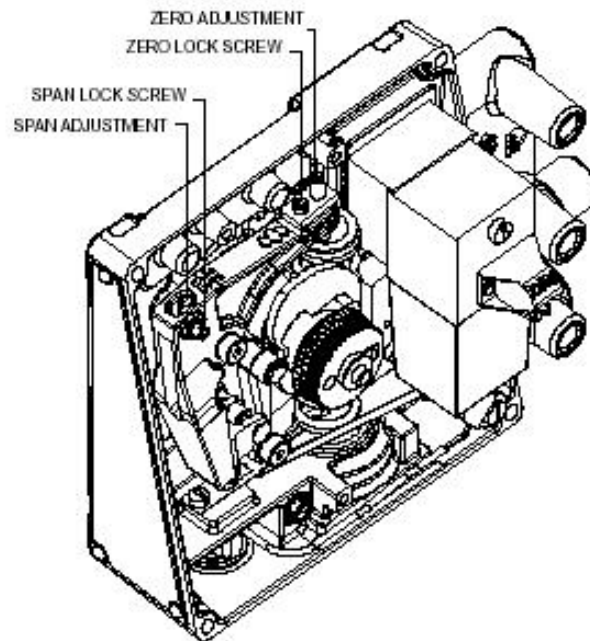

- 5.19 If span was changed on the positioner, then repeat Zero adjustment by repeating step 5.18.
- 5.20 Reinstall the positioner cover.
- 5.21 Turn on liquid nitrogen supply with doors closed, fans on, cooling event enabled, and 0% output (no temperature setpoint). Watch the chamber temperature to ensure that it does not slowly drop. If it does drop slowly, you should redo the Zero adjustment to ensure that at 0% output the valve closes tightly. Run a cooling setpoint to ensure valve is operating properly.